

Fluorescent Luminaire Industrial

MAINTENANCE FREE – SEALED FOR LIFE
10 year warranty *

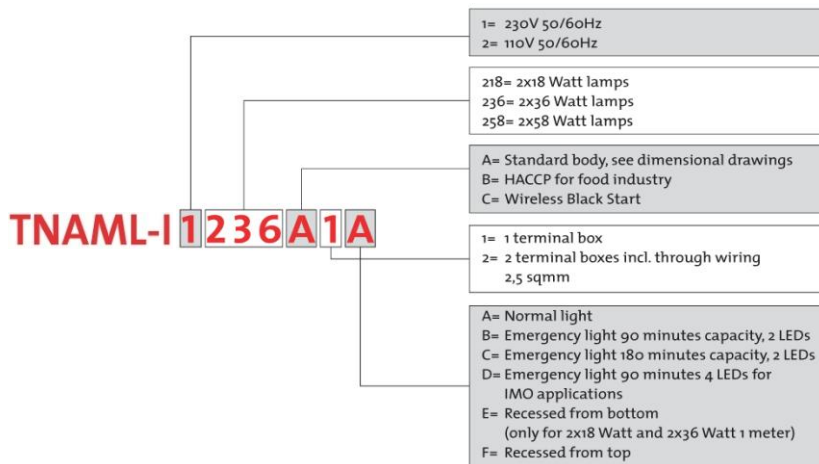
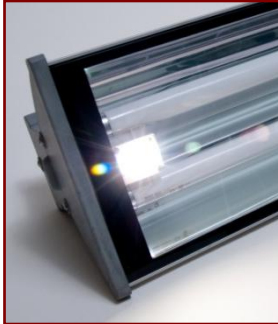

Features:

- ✚ Sealed for life construction – maintenance free design
- ✚ Fully Recyclable
- ✚ Seawater resistant anodised aluminium (compliant with NORSOK M-121, structural aluminium)
- ✚ Electronic ballast with EOL protection, pre-heated start
- ✚ Pre-assembled long-life fluorescent lamps, colour 840
- ✚ Toughened glass lens
- ✚ Ambient temperature: -20°C to +55°C
Warranty: -20°C to +45°C (Standard); -20°C to +30°C (Emergency)
- ✚ Supply voltage: 220V-264Vac 50/60Hz
- ✚ Ingress protection: IP66/68 (J/B sealed with Terostat sealant)
- ✚ 90min battery backup time as standard.
- ✚ Self-testing: full function test at random every 100 days (RED error LED)
- ✚ Sliding mounting brackets for easy and quick installation
- ✚ Entries: 2xM25 clearance entries
- ✚ 0.5-6mm² spring terminals wired for single phase looping

Optional:

- ✚ Double junction box with 2.5mm² through wiring
- ✚ 110/120Vac, 50/60Hz
- ✚ Zone 1/Zone 2 versions
- ✚ Flying lead with sealed junction box, cable to customer specification
- ✚ M25-M20 reducers
- ✚ 180min battery backup
- ✚ Wireless 'BLACK START' facility
- ✚ HACCP compliant (report DEKRA 06540)



Dimensions:

Type	Single JB (mm)	Double JB (mm)
2x18W Std	720	790
2x18W EM	880	950
2x36W Std/EM	1330	1400
2x58W Std/EM	1630	1700

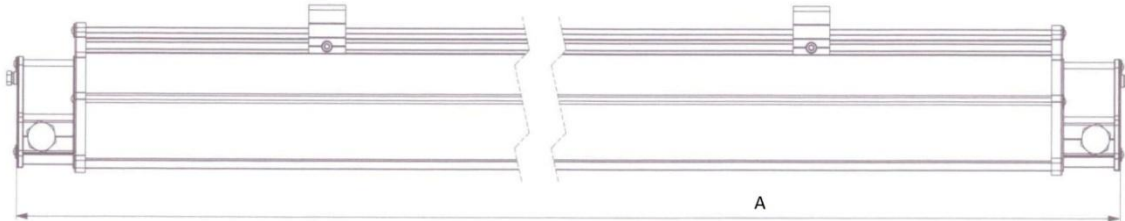
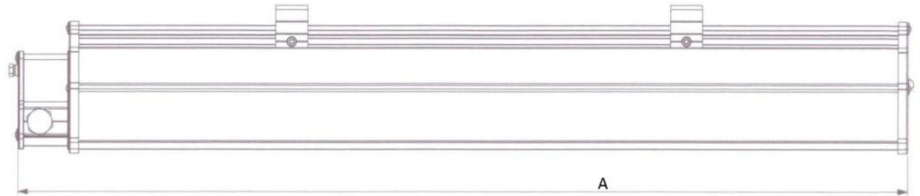
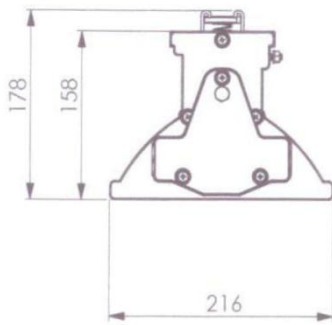

Light distribution curve:

2xT8

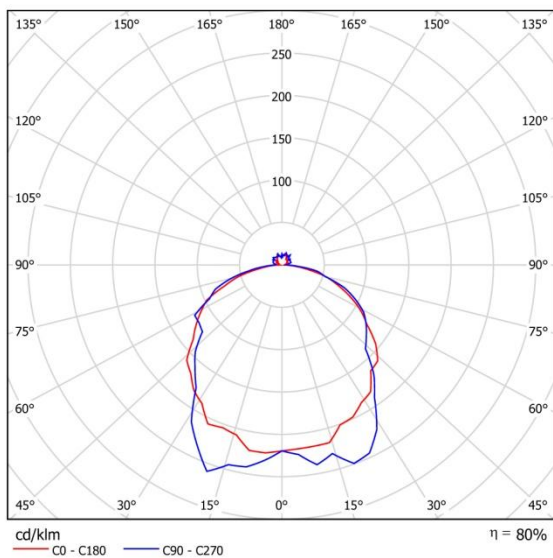

2xLED

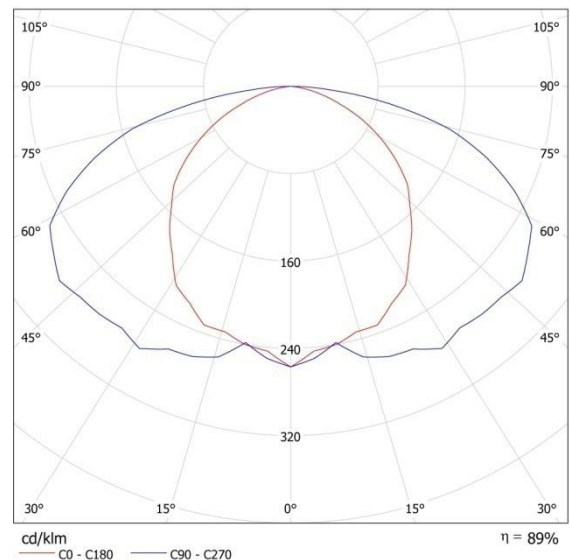

Mounting options:



SAFE answers to HAZARDOUS questions