

EPKMZ

The EPKMZ Motor-Protective Circuit Breakers are based on our EFQL Ex d enclosure manufactured in copper free aluminium and painted according to RAL 6003. The EPKMZ range can be delivered with automatic circuit breakers, on-load switches and selector switches up to 63A and is suitable for use indoor or outdoor, in corrosive and hazardous areas where gases, vapours and dusts may be present.

Specifications

Material	Copper-free aluminium (Cu<0.1%)
IP Rating	IP66-67 with flanged joint coated with silicone grease (contact our sales dept. for detailed reference)
Temperature	-30°C to 55°C
Approvals	
- ATEX	INERIS 02ATEX0027X
- GOST	GOST Certificate
Standards	EN/IEC: 60079-0, 60079-1, 60079-7, 60079-18, EN: 61241-0, 61241-1
Ex-code	Ⓔ II 2 GD Ex d IIB T6 Ex tD A21 IP66 T85°C According to European Directive 94/9/EC (ATEX) For Zone 1 / Zone 2, Zone 21 / Zone 22
Surface treatment	External polyurethane painting (RAL 6003)
Entries	No 2 Entries diam. 1" or M32
Standard Identification	Identification nameplate is realized in high resistance self-adhesive polyester with thermal transfer inscriptions
Poles	3 Poles
Voltage	220/660V 50/60Hz
Accessories	Customized colors Overload and short circuit releases
Note	Foreseen with electrical unit up to 63 A External operating handle



Dimensions EFQL - 4

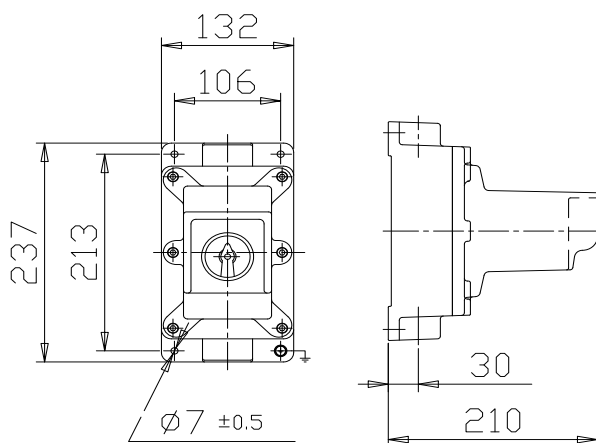

EPKMZ

Item	Note	Weight [kg]
TYPE EFQL - 3	Compatible until No. 8 steps of 9 [mm] (MULTI-9)	3.250
TYPE EFQL - 4	Compatible until No. 10 steps of 9 [mm] (MULTI-9)	4.600



STL International Ltd
Hill Farm, Linton Hill
Linton, Maidstone
Kent. ME17 4AL
United Kingdom
tel. +44 (0)1622 749633
fax. +44 (0)1622 746800
email. solutions@stl-int.co.uk
web. www.stl-int.co.uk