



# BH24-LED

## 5 year warranty

IP 65

**Wall or ceiling mounted bulkhead for use in demanding applications.**

**LED Applications:** Tunnels, Marine, Coastal areas  
(1000hr salt spray test approved)

**Body:** Aluminium alloy, RAL 9005, black

**Diffuser:** Hardened clear safety glass

**Light source:** LED, 4000K, CRI >80, 2400 lumen

**Ambient Temperature:** -25°C to +50°C

**LED modules (calculated):** L80B10 @ta50°C - 50,000hrs

**Supply:** 220-240V 50/60Hz, 24W

**Entry:** 2 x M20 (one top and one bottom)

**Termination:** 2.5mm<sup>2</sup> max

**Mounting:** Flange mounted

- Optional:**
- 316SS cage guard
  - Integrated 3hr emergency
  - Self-testing emergency
  - Dusk to Dawn
  - Microwave motion sensor
  - Daylight monitoring

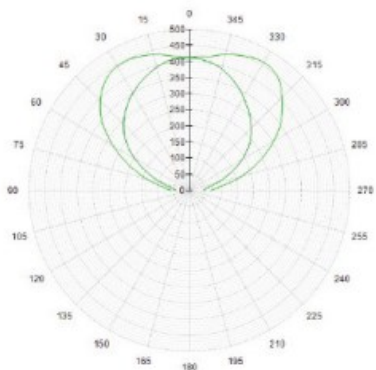
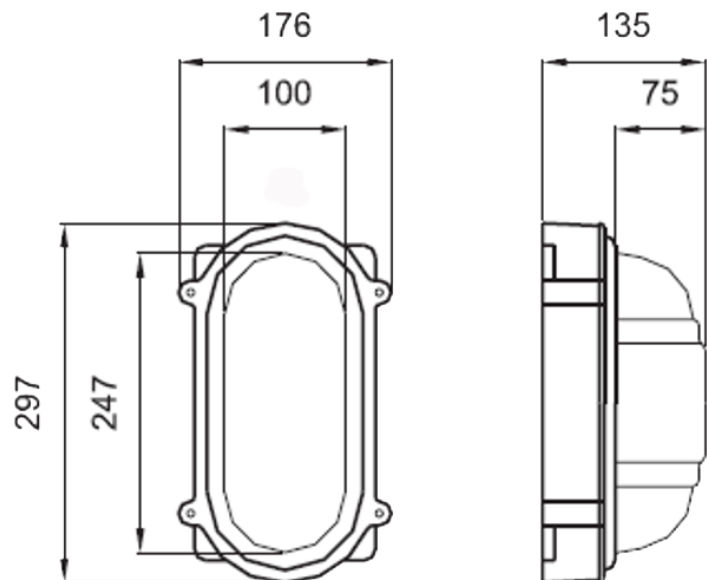

Photometric data

